

# SAMSONmaxi

Art.No.	Type
---------	------

**650-202-206-K2** SAMSONmaxi park fitting excl pole. E27. CL.II. Opal white PC-screen. Hot galvanized steel.

**Recommended Light Sources:**

- 982-77-17-03-CL** Phillips TrueForce Core Road LED 17W. E27. 25000h. 2800Lm. 3000K.
- 982-77-17-04-CL** Phillips TrueForce Core Road LED 17W. E27. 25000h. 3000Lm. 4000K.
- 982-76-21-03-CL** Phillips TrueForce LED HPL ND 21W. E27. 50000h. 2850Lm. 3000K.
- 982-76-21-04-CL** Phillips TrueForce LED HPL ND 21W. E27. 50000h. 3000Lm. 4000K.

**Accessories:**

- 802-70-035-2** Ø60/117mm conical pole. LPH 3,50M f/burial. 4,10/3,50M. Hot galvanized steel.
- 800-145-500** Insulation sleeve (foam block) Ø135/60 for poles Ø133/Ø108mm.
- 920-634-200** Turn securing for Ø108/Ø133mm pole. Hot galvanized plate.
- 924-100-002** Fuse inset MINI for Ø108/Ø133mm poles (fits to LPH 2,50M and 3,00M).
- 800-13-108-2** Bracket f/OPUS74 outlet (excl). Fits t/Ø108mm pole. Hot galvanized steel.
- 920-67-6502-18** Cover screen 180°. Hot galvanized plate. (Also available in 120°)  
----- Several variations of poles, accessories and spare parts. See page 103-130 -----

- Variation options:**
- For Ø133mm cylindrical pole.
  - With wall arm.

- Key features:**
- 10 year anti-corrosion warranty (hot galvanized).
  - 10 year reorder warranty.
  - Easy light source change and great flexibility with retrofit LED.
  - Supplied with 3,5M cable.

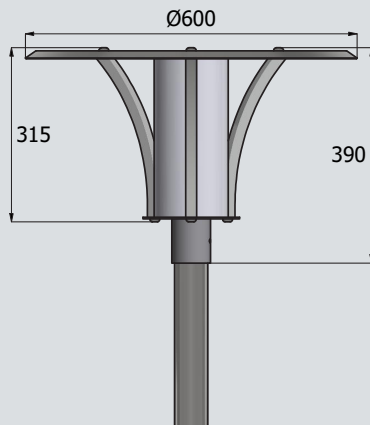

daidsuperlight.dk

